

1 2 3 4 5 6 7 8

RoHS REACH	Rev.	Description	Date	Drawn	Checked
------------	------	-------------	------	-------	---------

A

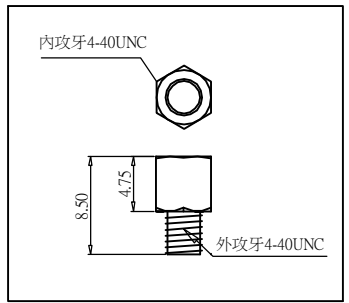
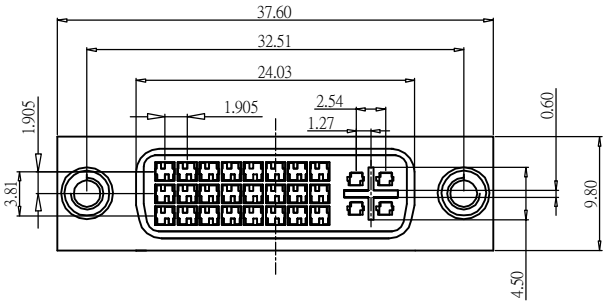

***MATERIAL**
 BODY : PA66+30% UL 94V-0 RATED, COLOR: BEIGE
 CONTACTS : BRASS
 CONTACT PLATING : GOLD PLATING OVER NICKEL ON CONTACT AREA TIN PLATING ON TERMINAL

***MECHANICAL**
 MATING FORCE : 4.5 KG MAX. @ 25 MM/MINUTE
 UNMATING FORCE: 1.0 KG MIN. AND 4.0 KG MAX. @25 MM/MINUTE
 DURABILITY: 100 MATING CYCLES

***ELECTRICAL SPECIFICATION**
 INSULATION RESISTANCE : 1000 MEGOHMS MIN
 DIELECTRIC WITHSTANDING VOLTAGE : 500 V DC RMS ±50 V.60 HZ
 CURRENT RATING: 1.5 AMPERES MIN
 SHELL RESISTANCE: 50 MILIOHMS MAX.INITIAL; 50 MILIOHMS MAX.CHANGE FROM INITAL
 CONTOCT RESISTANCE : 20 MILLOHMS MAX.

***ENVIRONMENTAL**
 OPERRATING TEMPERATURE : -20°TO85°

***HOW TO ORDER**

B

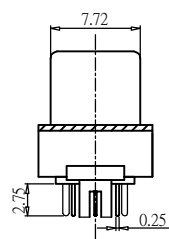
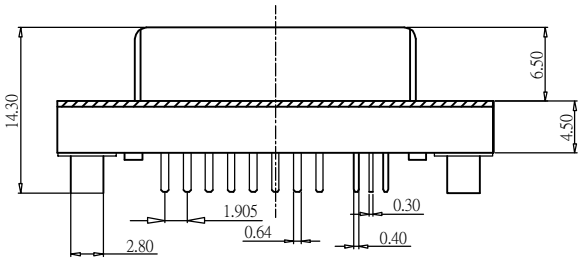

801D - 24+5 F 8 8 2 Z - XX - LF

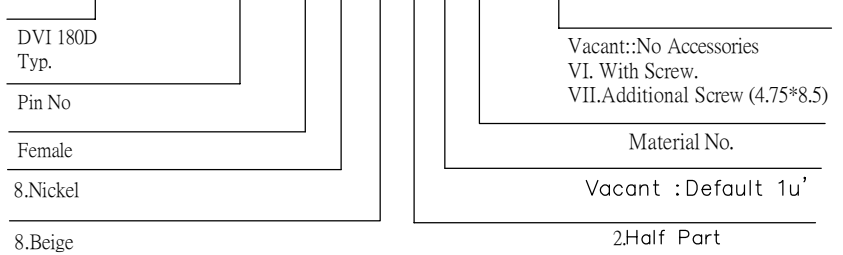

C

D

E

F

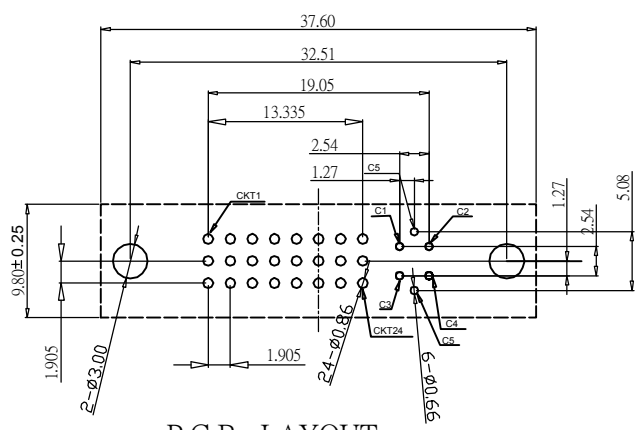

P.C.B LAYOUT

GENERAL TOLERANCE: .X ±0.35 .XX ±0.25 .XXX ±0.15		DRAWN : SHC		慶崙企業股份有限公司 <i>CHINSHONG ENTERPRISE CO.,LTD.</i>	
UNIT: mm		APPROVED :			
SCALE: Free		DATE: 06.05.06		TITLE DVI(24+5)F180度	
PROJECTION:		VERSION: A/1		PART No. 801D-24+5F882Z-XX-LF	
DWG. No.					

1 2 3 4 5 6 7 8